

SMALL SIZE HIGH STABILITY TCXO MV120

Features:

- Excellent frequency stability vs. temperature
- Wide operating temperature range
- Frequency range 9.6-20.0 MHz

ORDERING GUIDE: MV120 – B – 1500 – K – LN – 10.0 MHz

Availability of certain stability vs. operating temperature range		$\pm 2 \times 10^{-6}$	$\pm 1.5 \times 10^{-6}$	$\pm 1.0 \times 10^{-6}$	$\pm 7.0 \times 10^{-7}$
		2000	1500	1000	700
A	0...+55 °C	A	A	A	A
B	- 10...+60 °C	A	A	A	C
C	- 20...+70 °C	A	A	A	NA
D	-40...+70 °C	A	A	C	NA

For other temperature ranges see designation at the end of Data Sheet

	Availability of certain aging values for certain frequencies	Standard frequencies		
		9.8304 MHz	10.0 MHz	12.8 MHz
M	$\pm 3 \times 10^{-6}$ /year	A	A	A
L	$\pm 2 \times 10^{-6}$ /year	A	A	A
K	$\pm 1 \times 10^{-6}$ /year	A	A	A

A – available, NA – not available, C – consult factory

Package drawing and pin designation

1. Frequency adjustment
2. GND
3. RF-output
4. Power supply

Pins #1 and #2 are connected by technological resistor to adjust the frequency. This resistor can be removed in time of installation of the oscillator to an electronic device providing the same resistance between the pins #1 and #2.

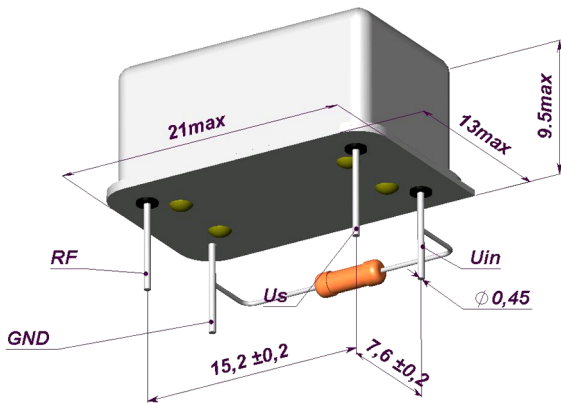

Additional notes:

For non standard operating temperature ranges please use the following two letters designations (first letter for the lower limit, second letter for the upper limit), °C:

A	B	C	D	E	F	G	H	J	K	L	M	N	P	Q	R	S	T	U	W	X
-60	-55	-50	-45	-40	-30	-20	-10	0	+10	+30	+40	+45	+50	+55	+60	+65	+70	+75	+80	+85

Output	SIN	
Level	200... 350 mV	
Load	500 Ohm $\pm 10\%$	
Phase noise (dBc/Hz) at offset (for 10 MHz): 1 Hz	-	LN*
	-60	-65
10 Hz	-90	-95
100 Hz	-120	-120
1000 Hz	-140	-140

* For frequencies 9.6 - 12.8 MHz

Short term stability (Allan deviation) per 1 s	$< 1.0 \times 10^{-9}$
Frequency stability vs. load changes	$< \pm 3.0 \times 10^{-7}$
Frequency stability vs. power supply changes	$< \pm 2.0 \times 10^{-7}$
Power supply (Us)	12 V (+5%, -30%)
Current consumption	< 5 mA
Start-up time	< 1 s
Frequency pulling range	$> \pm 8.5 \times 10^{-6}$
Harmonics suppression	> 30 dB

Storage temperature range	-50...+70 °C
Vibrations	1-500 Hz, 10 g
Shock	500 g, 2 ms
Sealing	hermetical
Humidity @ +25 °C	98%