

PRECISION OCXO MV172

Features:

- High stability vs. temperature - up to $\pm 1 \times 10^{-9}$
- Low aging - up to $\pm 1 \times 10^{-8}$ /year
- Low phase noise
- 5V or 12V power supply
- Available as RoHS
- Frequency range 4.096-20.0 MHz

Output type	
SIN	
HCMOS	
Power Supply	
12V	
5V	
Package type	
Z25	50.8x50.8x25 mm
Z19	50.8x50.8x19 mm

ORDERING GUIDE: MV172 – B 1 E – SIN – 5V – Z25 – 5.0 MHz

Availability of certain stability vs. operating temperature range		$\pm 1 \times 10^{-8}$	$\pm 5 \times 10^{-9}$	$\pm 2 \times 10^{-9}$	$\pm 1 \times 10^{-9}$
		10	5	2	1
A	0...+55 °C	A	A	A	A
B	- 10...+60 °C	A	A	A	A*
C	- 20...+70 °C	A	A	A*	C*
D	- 40...+70 °C	A	A*	C*	C*
EX	- 40...+85 °C	A*	C	C	NA

* for 25mm height

Availability of certain aging values for certain frequencies		Standard frequencies	
		5.0 MHz (5 x k) MHz	4.096 MHz (4.096 x k) MHz
E	$\pm 3 \times 10^{-8}$ /year	A	A
D	$\pm 2 \times 10^{-8}$ /year	A	A
C	$\pm 1 \times 10^{-8}$ /year	A	A

A – available, NA – not available, C – consult factory

A – available, NA – not available, C – consult factory
+75 °, +80 °, +85 °C upper temperature limits may be available on a separate request. For other temperature ranges see designation at the end of Data Sheet.

Package drawing:

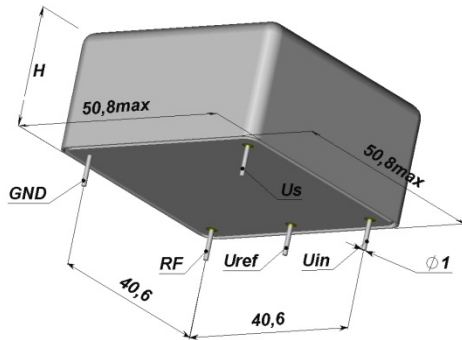

H=25 mm for Z25; H=19 mm for Z19.

Short term stability per 1 sec (for 5MHz)	$< 2 \times 10^{-12}$	
Frequency stability vs. load changes	$< \pm 5 \times 10^{-10}$	
Frequency stability vs. power supply changes	$< \pm 5 \times 10^{-10}$	
Warm-up time within accuracy of $< \pm 2 \times 10^{-8}$ @ 25°C	< 8 min	
Power supply (Us)	5V $\pm 5\%$	12V $\pm 5\%$
Steady state current consumption @ 25°C	< 500 mA	< 200 mA
Peak current consumption during warm-up (for "D" temp. range)	< 1.2 A	< 0.6 A
Frequency pulling range	$> \pm 3.0 \times 10^{-7}$	
with external voltage range (Uin)	0...+4.5 V	0...+5 V
with external potentiometer	20 kOhm	
Reference voltage (Uref)	+4.5 V	+5 V
Slope	Negative (positive)	

Vibrations:	
Frequency range	10-200 Hz
Acceleration	5g
Shock:	
Acceleration	75 g
Duration	3 ± 1 ms
Storage temperature range	-55...+85 °C

Output	SIN
Level	> 300 mV
Load	50 Ohm $\pm 5\%$
Harmonic suppression	> 30 dBc (standard) (> 50 optional)
Phase noise (for 5 MHz)	
@ 1 Hz	< -100 dBc/Hz
10 Hz	< -130 dBc/Hz
100 Hz	< -145 dBc/Hz
1000 Hz	< -150 dBc/Hz
10000 Hz	< -155 dBc/Hz

Additional notes:

- Please consult factory for daily aging values. Normally typical correspondence of daily aging (after 30 days of operation) to aging per year is as following: $\pm 3 \times 10^{-8}$ /year - $\pm 3 \times 10^{-10}$ /day; $\pm 2 \times 10^{-8}$ /year - $\pm 2 \times 10^{-10}$ /day; $\pm 1 \times 10^{-8}$ /year - $\pm 1 \times 10^{-10}$ /day.
- Please mention RoHS requirement (if any) while requesting for quote or while placing PO.
- For non standard operating temperature ranges please use the following two letters designations (first letter for the lower limit, second letter for the upper limit), °C:

A	B	C	D	E	F	G	H	J	K	L	M	N	P	Q	R	S	T	U	W	X
-60	-55	-50	-45	-40	-30	-20	-10	0	+10	+30	+40	+45	+50	+55	+60	+65	+70	+75	+80	+85