

# MINIATURE PRECISION OCXO MV197

## Features:

- Package height from 16 mm, down to 10 mm
- High stability vs. temperature: up to  $\pm 5 \times 10^{-10}$
- Long term stability up to  $\pm 2 \times 10^{-8}$ /year
- Low phase noise option
- Fast warm-up time up to 1 min
- Available as RoHS
- Frequency range: 8.192 – 20.0 MHz

Power supply		Output		Package type	
12V		SIN		36x27x16 mm	B16
5V		HCMOS		36x27x12.7 mm	B12.7
				36x27x10 mm	B10

## ORDERING GUIDE: MV197– C 3 F – 12V – SIN – B12.7 – LN – 10.0 MHz

Availability of certain stability vs. operating temperature range (for 10 MHz)		$\pm 5 \times 10^{-9}$	$\pm 3 \times 10^{-9}$	$\pm 2 \times 10^{-9}$	$\pm 1 \times 10^{-9}$	$\pm 7.5 \times 10^{-10}$	$\pm 5 \times 10^{-10}$
		5	3	2	1	075	05
A	0...+55 °C	A	A	A	A	A	A
B	- 10...+60 °C	A	A	A	A	A	A
C	- 20...+70 °C	A	A	A	A	A*	A*
D	- 40...+70 °C	A	A	A	A	A*	A*
EX	- 40...+85 °C	A	A	A	A	A*	C

\* - "C" for B10 package.

A – available, NA – not available, C – consult factory

For other temperature ranges see designation at the end of Data Sheet.

Availability of certain aging values for certain frequencies		Standard frequencies				
		10.0 MHz	12.8 MHz	13.0 MHz	16.384 MHz	20.0 MHz
H	$\pm 2 \times 10^{-7}$ /year	A	A	A	A	A
G	$\pm 1 \times 10^{-7}$ /year	A	A	A	A	C
F	$\pm 5 \times 10^{-8}$ /year	A	A	A	C	NA
E	$\pm 3 \times 10^{-8}$ /year	A	C	C	NA	NA
D*	$\pm 2 \times 10^{-8}$ /year	A	C	NA	NA	NA

\* - only for B16 package

Phase noise, dBc/Hz, for 10MHz		LN	ULN
		For 12V, SIN	
1 Hz	<-95	<-100	<-103
10 Hz	<-125	<-130	<-133
100 Hz	<-145	<-153	<-155
1000 Hz	<-150	<-158	<-160
10000 Hz	<-155	<-160	<-161

## Package drawings:

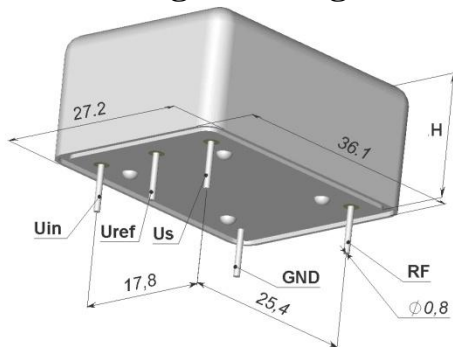

For "H" definition please see package type

Short term stability (Allan deviation) per 1 sec, for 10 MHz	$< 5 \times 10^{-12}$
Optional*	$< 2 \times 10^{-12}$
Frequency stability vs. load changes ( $\pm 5\%$ )	$< \pm 5 \times 10^{-10}$
Optional*	$< \pm 2 \times 10^{-10}$
Frequency stability vs. power supply changes ( $\pm 5\%$ )	$< \pm 5 \times 10^{-10}$
Optional*	$< \pm 2 \times 10^{-10}$
Warm-up time within accuracy of $< \pm 2 \times 10^{-8}$ @ 25°C	<3 min
Optional*, within accuracy of $< \pm 1 \times 10^{-7}$ @ 25°C	<1 min

Vibrations:	
Frequency range	10-200 Hz
Acceleration	5 g
Shock:	
Acceleration	75 g
Duration	3±1 ms
Humidity @ 25 °C	98%
Storage temperature range	-55...+85 °C

\* Available on request

## Additional notes:

- Start-up time < 100 mSec – optional.
- Please consult factory for daily aging values. Normally typical correspondence of daily to aging per year is as following:  $\pm 1 \times 10^{-7}$ /year –  $\pm 1 \times 10^{-9}$ /day;  $\pm 5 \times 10^{-8}$ /year –  $\pm 5 \times 10^{-10}$ /day;  $\pm 3 \times 10^{-8}$ /year –  $\pm 3 \times 10^{-10}$ /day
- Please mention RoHS requirement (if any) while requesting for quote or while placing PO.
- For non standard operating temperature ranges please use the following two letters designations (first letter for the lower limit, second letter for the upper limit), °C:

A	B	C	D	E	F	G	H	J	K	L	M	N	P	Q	R	S	T	U	W	X
-60	-55	-50	-45	-40	-30	-20	-10	0	+10	+30	+40	+45	+50	+55	+60	+65	+70	+75	+80	+85

Power supply (Us)	12V±5%	5V±5%
Steady state current consumption @ +25°C	<150 mA	<400 mA
Peak current consumption during warm-up (for "D" temp. range)	<400 mA	<1000 mA
Frequency pulling range (for 10 MHz)	$> \pm 4.0 \times 10^{-7}$	
Control voltage range (Uin)	0...5 V	0...4.5 V
Reference voltage (Uref)	+5 V	+4.5 V
Output	HCMOS	SIN
Level	"0"	<0.5V
	"1"	>4.0V
Load	10kOhm/30pF	50 Ohm±5%
Rise/Fall time	<6 ns (<3 ns optional)	-
Harmonics	-	>30 dBc