

MINIATURE PRECISION OCXO MV205

PRELIMINARY INFORMATION

Features:

- Package height from 16 mm, down to 10 mm
- High stability vs. temperature: up to $\pm 1 \times 10^{-9}$
- Long term stability up to $\pm 2 \times 10^{-8}$ /year
- Fast warm-up time up to 1 min
- Available as RoHS
- Frequency range: 16.384 ... 40.0 MHz

Power supply		Output		Package type	
12V		SIN		36x27x16.0 mm *	B16
5V		HCMOS		36x27x12.7 mm	B12.7
				36x27x10.0 mm	B10

* - package is available by customer's request

ORDERING GUIDE: MV205 - C3G - 12V - SIN - B12.7 - 20.0 MHz

Availability of certain stability vs. operating temperature range		$\pm 5 \times 10^{-9}$	$\pm 3 \times 10^{-9}$	$\pm 2 \times 10^{-9}$	$\pm 1 \times 10^{-9}$
A	0...+55 °C	A	A	A	A
B	-10...+60 °C	A	A	A	A
C	-20...+70 °C	A	A	A	A
D	-40...+70 °C	A	A	A	C
EX	-40...+85 °C	A	C	C	C

A – available, NA – not available, C – consult factory

For other temperature ranges see designation at the end of Data Sheet.

Availability of certain aging values for certain frequencies		Standard frequencies					
		16.384MHz (8.192x2)	20.0MHz (10.0x2)	25.6MHz (12.8x2)	26.0MHz (13.0x2)	32.768MHz (16.384x2)	40.0 MHz (20.0x2)
H	$\pm 2 \times 10^{-7}$ /year	A	A	A	A	A	A
G	$\pm 1 \times 10^{-7}$ /year	A	A	A	A	C	C
F	$\pm 5 \times 10^{-8}$ /year	A	A	A	C	NA	NA
E	$\pm 3 \times 10^{-8}$ /year	A	C	C	NA	NA	NA
D	$\pm 2 \times 10^{-8}$ /year	A	C	NA	NA	NA	NA

Phase noise, dBc/Hz, for 20MHz(10MHz x 2), SIN	
1 Hz	<-90
10 Hz	<-120
100 Hz	<-140
1000 Hz	<-145
10000 Hz	<-150

Package drawings:

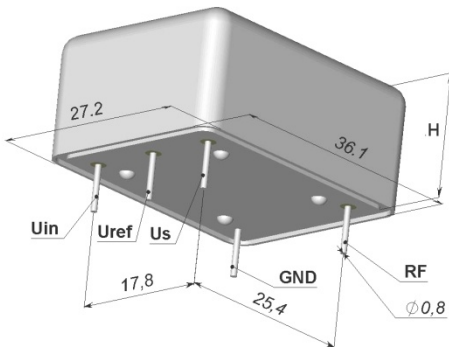

For "H" definition please see package type

Vibrations:	
Frequency range	10-200 Hz
Acceleration	5 g

Shock:	
Acceleration	75 g
Duration	3±1 ms

Humidity @ 25 °C	98%
Storage temperature range	-55...+85 °C

Short term stability (Allan deviation) per 1 sec, for 20 MHz (10MHz x 2)	< 5×10^{-12}
Optional	< 2×10^{-12}
Frequency stability vs. load changes ($\pm 5\%$)	< $\pm 5 \times 10^{-10}$
Frequency stability vs. power supply changes ($\pm 5\%$)	< $\pm 5 \times 10^{-10}$
Warm-up time within accuracy of $\pm 2 \times 10^{-8}$ @ 25°C	<3 min
Optional, within accuracy of $\pm 1 \times 10^{-7}$ @ 25°C	<1 min

Power supply (Us)	12V±5%	5V±5%
Steady state current consumption @ +25°C	<150 mA	<400 mA
Peak current consumption during warm-up (for "D" temp. range)	<400 mA	<1000 mA
Frequency pulling range	$>\pm 4.0 \times 10^{-7}$	
Control voltage range (Uin)	0...5 V	0...4.5V
Reference voltage (Uref)	+5 V	+4.5 V

Output	HCMOS		SIN
Level	"0"	<0.5V	>300 mV
	"1"	>4.0V	
Load	10kOhm/30pF		50 Ohm±5%
Harmonics	-		<-30 dBc

Additional notes:

- Please consult factory for daily aging values. Normally typical correspondence of daily to aging per year is as following: $\pm 1 \times 10^{-7}$ /year – $\pm 1 \times 10^{-9}$ /day; $\pm 5 \times 10^{-8}$ /year – $\pm 5 \times 10^{-10}$ /day; $\pm 3 \times 10^{-8}$ /year – $\pm 3 \times 10^{-10}$ /day
- Please mention RoHS requirement (if any) while requesting for quote or while placing PO.
- For non standard operating temperature ranges please use the following two letters designations (first letter for the lower limit, second letter for the upper limit), °C:

A	B	C	D	E	F	G	H	J	K	L	M	N	P	Q	R	S	T	U	W	X
-60	-55	-50	-45	-40	-30	-20	-10	0	+10	+30	+40	+45	+50	+55	+60	+65	+70	+75	+80	+85