

HIGH STABILITY MINIATURE OCXO MV285

PRELIMINARY INFORMATION

Features:

- Small package – 1”x1”x0.5” (25x25x12.7 mm)
- High stability vs. temperature: up to $\pm 1 \times 10^{-9}$
- Long term stability up to $\pm 3 \times 10^{-8}$ /year
- Available as RoHS
- Frequency range: 8.192 – 20.0 MHz

| Power supply | Output |
|--------------|--------|
| 12V | SIN |
| 5V | HCMOS |

ORDERING GUIDE: MV285 – C 3 F – 12V – SIN – 10.0 MHz – LN

| Availability of certain stability vs. operating temperature range | | $\pm 5 \times 10^{-9}$ | $\pm 3 \times 10^{-9}$ | $\pm 2 \times 10^{-9}$ | $\pm 1 \times 10^{-9}$ |
|---|---------------|------------------------|------------------------|------------------------|------------------------|
| A | 0...+55 °C | A | A | A | A |
| B | - 10...+60 °C | A | A | A | A |
| C | - 20...+70 °C | A | A | A | C |
| D | - 40...+70 °C | A | A | A | C |
| EX | - 40...+85 °C | A | A | C | C |

A – available, NA – not available, C – consult factory

For other temperature ranges see designation at the end of Data Sheet.

| Availability of certain aging values for certain frequencies | | Standard frequencies | | | | |
|--|-------------------------------|----------------------|----------|----------|------------|----------|
| | | 10.0 MHz | 12.8 MHz | 13.0 MHz | 16.384 MHz | 20.0 MHz |
| H | $\pm 2 \times 10^{-7}$ / year | A | A | A | A | A |
| G | $\pm 1 \times 10^{-7}$ / year | A | A | A | A | C |
| F | $\pm 5 \times 10^{-8}$ / year | A | A | A | C | NA |
| E | $\pm 3 \times 10^{-8}$ / year | A | C | C | NA | NA |

A – available, NA – not available, C – consult factory

Package drawing:

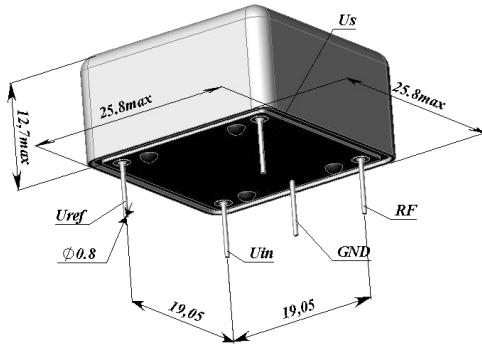

| Phase noise, dBc/Hz, for 10MHz, SIN | LN | |
|-------------------------------------|--------------|-------|
| | For 12V, SIN | |
| 1 Hz | <-95 | <-100 |
| 10 Hz | <-125 | <-130 |
| 100 Hz | <-145 | <-150 |
| 1000 Hz | <-150 | <-157 |
| 10000 Hz | <-155 | <-159 |

| | |
|--|---------------------------|
| Short term stability (Allan deviation) per 1 sec, for 10 MHz | $< 5 \times 10^{-12}$ |
| Option* | $< 2 \times 10^{-12}$ |
| Frequency stability vs. load changes ($\pm 5\%$) | $< \pm 5 \times 10^{-10}$ |
| Frequency stability vs. power supply changes ($\pm 5\%$) | $< \pm 2 \times 10^{-10}$ |
| Warm-up time within accuracy of $< 2 \times 10^{-8}$ @ 25 °C | <3 min |
| Optional*, within accuracy of $< 1 \times 10^{-7}$ @ 25 °C | <1 min |

| | |
|-----------------|-----------|
| Vibrations: | |
| Frequency range | 10-200 Hz |
| Acceleration | 5 g |

| | |
|--------------|--------------|
| Shock: | |
| Acceleration | 75 g |
| Duration | 3 \pm 1 ms |

| | |
|---------------------------|--------------|
| Humidity @ 25 °C | 98% |
| Storage temperature range | -55...+85 °C |

| Power supply (Us) | 12V \pm 5% | 5V \pm 5% |
|---|----------------------------|-----------------|
| Steady state current consumption @ 25°C | <170 mA | <400 mA |
| Peak current consumption during warm-up (for “D” temp. range) | <400 mA | <1000 mA |
| Frequency pulling range (for 10 MHz) | $> \pm 4.0 \times 10^{-7}$ | |
| Control voltage range (Uin) | 0...5 V | 0...4.5V |
| Reference voltage (Uref) | +5 V | +4.5 V |
| Output | HCMOS | SIN |
| Level | “0” | <0.5V |
| | “1” | >4.0V |
| Load | 10kOhm/30pF | 50 Ohm \pm 5% |
| Rise/Fall time | <6 ns (<3 ns optional) | - |
| Harmonics | - | >30 dBc |

Additional notes:

- Please consult factory for daily aging values. Normally typical correspondence of daily to aging per year is as following: $\pm 1 \times 10^{-7}$ /year – $\pm 1 \times 10^{-9}$ /day; $\pm 5 \times 10^{-8}$ /year – $\pm 5 \times 10^{-10}$ /day; $\pm 3 \times 10^{-8}$ /year – $\pm 3 \times 10^{-10}$ /day
- Please mention RoHS requirement (if any) while requesting for quote or while placing PO.
- For non standard operating temperature ranges please use the following two letters designations (first letter for the lower limit, second letter for the upper limit), °C:

| A | B | C | D | E | F | G | H | J | K | L | M | N | P | Q | R | S | T | U | W | X |
|-----|-----|-----|-----|-----|-----|-----|-----|---|-----|-----|-----|-----|-----|-----|-----|-----|-----|-----|-----|-----|
| -60 | -55 | -50 | -45 | -40 | -30 | -20 | -10 | 0 | +10 | +30 | +40 | +45 | +50 | +55 | +60 | +65 | +70 | +75 | +80 | +85 |