

LOW POWER CONSUMPTION OCXO WITH EXCELLENT SHORT TERM STABILITY AND EXTREMELY LOW PHASE NOISE MV83M

Features:

- Excellent short-term stability - up to $<5 \times 10^{-13}$ per 1 sec
- High stability - up to $\pm 5 \times 10^{-9}$
- Excellent phase noise
- Low power consumption
- Low aging - up to $\pm 3 \times 10^{-8}$ /year
- Frequencies 5.0 & 10.0 MHz

Frequency	
5.0 MHz	
10.0 MHz	
Short term stability (Allan deviation) per 1 sec.	
05	$<5 \times 10^{-13}$
1	$<1 \times 10^{-12}$
2	$<2 \times 10^{-12}$
3	$<3 \times 10^{-12}$

Aging	
G	$\pm 1 \times 10^{-7}$ /year
F	$\pm 5 \times 10^{-8}$ /year
E	$\pm 3 \times 10^{-8}$ /year

ORDERING GUIDE: MV83M – C 10 F – 5.0 MHz – 2 – LN

Availability of certain stability vs. operating temperature range		Stability					
		$\pm 5 \times 10^{-8}$	$\pm 3 \times 10^{-8}$	$\pm 2 \times 10^{-8}$	$\pm 1 \times 10^{-8}$	$\pm 7.5 \times 10^{-9}$	$\pm 5 \times 10^{-9}$
		50	30	20	10	7	5
A	0...+55 °C	A	A	A	A	A	A
B	-10...+60 °C	A	A	A	A	C	C
C	-20...+70 °C	A	A	A	A	NA	NA
D	-40...+70 °C	A	A	A	C	NA	NA

A – available, NA – not available, C – consult factory.

For other temperature ranges see designation at the end of Data Sheet

Output	SIN (5 MHz)	SIN (10 MHz)
Level	>225 mV (0dBm)	225 (0dBm)
Load	50 Ohm±5%	50 Ohm
Harmonic	<-30dBc	<-30dBc
Sub Harmonic	-	<-35dBc
Phase noise typical, dBc/Hz	-	LN
1Hz	-100	-115
10 Hz	-135	-140
100 Hz	-150	-150
1000 Hz	-155	-155
10000 Hz	-158	-158

Package drawing:

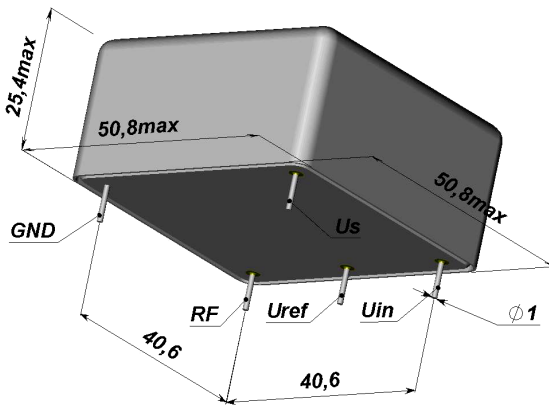

Frequency stability vs. load changes	$<\pm 1 \times 10^{-9}$
Frequency stability vs. power supply changes	$<\pm 1 \times 10^{-9}$
Power supply (Us)	12V±5%
Peak current consumption during warm-up	<400 mA
Steady state current consumption @ +25°C	<35 mA
Warm-up time within $\pm 5 \times 10^{-8}$ @ +25 °C	<5min
Frequency pulling range	$>\pm 3 \times 10^{-7}$
with external voltage range (Uin)	+1...+8V
with external potentiometer	20 kOhm
Reference voltage output (Uref)	+8V
Slope	Positive

Mechanical characteristics:

Storage temperature range	-55...+85 °C
Vibrations	10-500 Hz, 10 g
Shock	100g
Humidity @ +35 °C	98 %

Additional notes:

- Please consult factory for daily aging values. Normally typical correspondence of daily aging per day to aging per year is as following:
 $\pm 2 \times 10^{-7}$ /year - $\pm 2 \times 10^{-9}$ /day; $\pm 1 \times 10^{-7}$ /year - $\pm 1 \times 10^{-9}$ /day; $\pm 5 \times 10^{-8}$ /year - $\pm 5 \times 10^{-10}$ /day; $\pm 3 \times 10^{-8}$ /year - $\pm 3 \times 10^{-10}$ /day.
- For non standard operating temperature ranges please use the following two letters designations (first letter for the lower limit, second letter for the upper limit), °C:

A	B	C	D	E	F	G	H	J	K	L	M	N	P	Q	R	S	T	U	W	X
-60	-55	-50	-45	-40	-30	-20	-10	0	+10	+30	+40	+45	+50	+55	+60	+65	+70	+75	+80	+85