

# HIGH STABILITY MINIATURE OCXO MV85

## Features:

- Small package – 1”x1”x0.5” (25x25x12.7 mm)
- High stability vs. temperature - up to  $\pm 5 \times 10^{-9}$
- Low aging - up to  $\pm 3 \times 10^{-8}$ /year
- Low phase noise
- 3.3 V, 5V or 12V power supply
- Frequency range 10.0-30.0 MHz
- Available as RoHS

### Output type

SIN  
HCMOS

### Power supply

3.3 V  
5 V  
12 V

Phase noise, dBc/Hz, for 10-13 MHz, SIN	-	LN	ULN (10MHz)
1 Hz	<-85	<-95	<-95
10 Hz	<-115	<-120	<-125
100 Hz	<-140	<-140	<-145
1000 Hz *	<-150	<-150	<-150
10000 Hz *	<-155	<-155	<-155

\* - for 3.3 V: consult factory

## ORDERING GUIDE: MV85 – B 20 G – 5V – SIN – 10.0 MHz – LN

	Availability of certain stability vs. operating temperature range	Stability vs. temperature range					
		$\pm 1 \times 10^{-7}$	$\pm 5 \times 10^{-8}$	$\pm 3 \times 10^{-8}$	$\pm 2 \times 10^{-8}$	$\pm 1 \times 10^{-8}$	$\pm 5 \times 10^{-9}$
		100	50	30	20	10	5
A	0...+55 °C	A	A	A	A	A	A
B	-10...+60 °C	A	A	A	A	A	A
C	-20...+70 °C	A	A	A	A	A	C
D	-40...+70 °C	A	A	A	A	A	NA
EX	-40...+85 °C	A	A	A	A	C	NA

A – available, NA – not available, C – consult factory

	Availability of certain aging values for certain frequencies	Standard frequencies						
		10.0 MHz	12.8 MHz	13.0 MHz	16.384 MHz	20.0 MHz	25.0 MHz	30.0 MHz
H	$\pm 2 \times 10^{-7}$ /year	A	A	A	A	A	A	A
G	$\pm 1 \times 10^{-7}$ /year	A	A	A	A	C	C	C
F	$\pm 5 \times 10^{-8}$ /year	A	A	A	C	NA	NA	NA
E	$\pm 3 \times 10^{-8}$ /year	A	C	C	NA	NA	NA	NA

A – available, NA – not available, C – consult factory

## Package drawing:

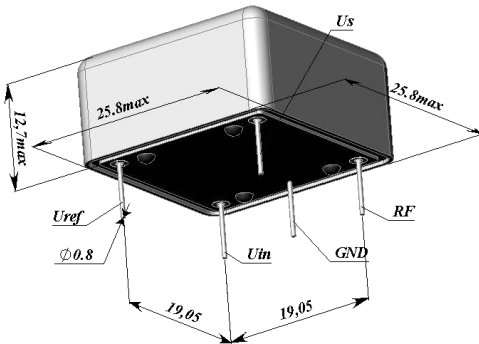

Frequency stability vs. load changes	< $\pm 5 \times 10^{-9}$		
Frequency stability vs. power supply changes	< $\pm 5 \times 10^{-9}$		
Warm-up time @ 25 °C within accuracy of $\pm 1 \times 10^{-7}$	<2 min		
Power supply (Us)	3.3V $\pm 5\%$	5V $\pm 5\%$	12V $\pm 5\%$
Steady state current consumption @ 25°C	<450 mA	<200 mA	<80 mA
Peak current consumption during warm-up	<1 A	<600 mA	<300 mA
Frequency pulling range	> $\pm 5 \times 10^{-7}$		
with external voltage range (Uin)	0...+3.0V	0...+4.5V	0...+5 V
with external potentiometer	20 kOhm		
Reference voltage output (Uref)	+3 V	+4.5 V	+5 V
Slope	Positive		

Frequencies, MHz	>10-13	>13-16	>16-20	>20-30	>13-16	>16-20	>20-30
Output	HCMOS				SIN		
Level	>4.0 V / 45...55%				>225 mV (0dBm)		
Load	10 kOhm/15 pF				50 Ohm $\pm 10\%$		
Harmonics	-				<-30 dBc		
Phase noise, dBc/Hz @ 1 Hz	<-90	<-80	<-75	<-70	<-90	<-75	<-70
10 Hz	<-120	<-105	<-100	<-95	<-120	<-105	<-100
100 Hz	<-140	<-130	<-130	<-130	<-140	<-135	<-135
1000 Hz *	<-145	<-145	<-145	<-145	<-150	<-150	<-150
10000 Hz *	<-150	<-150	<-150	<-150	<-155	<-155	<-155
Short term stability (Allan deviation) per 1 sec	< $1 \times 10^{-11}$	< $1 \times 10^{-11}$	< $2 \times 10^{-11}$	< $3 \times 10^{-11}$	< $1 \times 10^{-11}$	< $2 \times 10^{-11}$	< $3 \times 10^{-11}$

## Additional notes:

\* - for 3.3 V: consult factory

- Showed values of frequency stability vs. temperature usually are tested in Still Air test conditions. Please inform factory about different conditions in operation to provide appropriate tests.
- Please consult factory for daily aging values. Normally typical correspondence of daily aging per day to aging per year is as following:  $\pm 2 \times 10^{-7}$ /year -  $\pm 2 \times 10^{-9}$ /day;  $\pm 1 \times 10^{-7}$ /year -  $\pm 1 \times 10^{-9}$ /day;  $\pm 5 \times 10^{-8}$ /year -  $\pm 5 \times 10^{-10}$ /day.

A	B	C	D	E	F	G	H	J	K	L	M	N	P	Q	R	S	T	U	W	X
-60	-55	-50	-45	-40	-30	-20	-10	0	+10	+30	+40	+45	+50	+55	+60	+65	+70	+75	+80	+85

## Mechanical characteristics:

Vibrations:	
Frequency range	10-500 Hz
Acceleration	10g
Shock:	
Acceleration	100 g
Duration	3 $\pm 1$ ms
Humidity @ 25 °C	98%
Storage temperature range	-55...+80 °C